

# WarmFlo<sup>®</sup> Electric Furnace

**Electric Furnace** - features and performance, two steps above your basic electric furnace.

- WarmFlo controller - temperature sensing output and outdoor temperature sensing provide added comfort electric heat modulation **and** blower speed control for more uniform and comfortable heating

*The WarmFlo controller was introduced in 1997 and is a proven and customer accepted technique for providing the maximum comfort and efficiency from your electric unit.*

- ECM variable speed blower - highest efficiency in blower motors, continuous air at very high efficiency, automatically adjusts blower speed based on outdoor temperature and heat/cool modes

*Literally every gas furnace manufacturer now has a top-of-the-line furnace with the GE ECM variable speed blower. When incorporated with WarmFlo, this can provide additional operating efficiency and another level of comfort.*

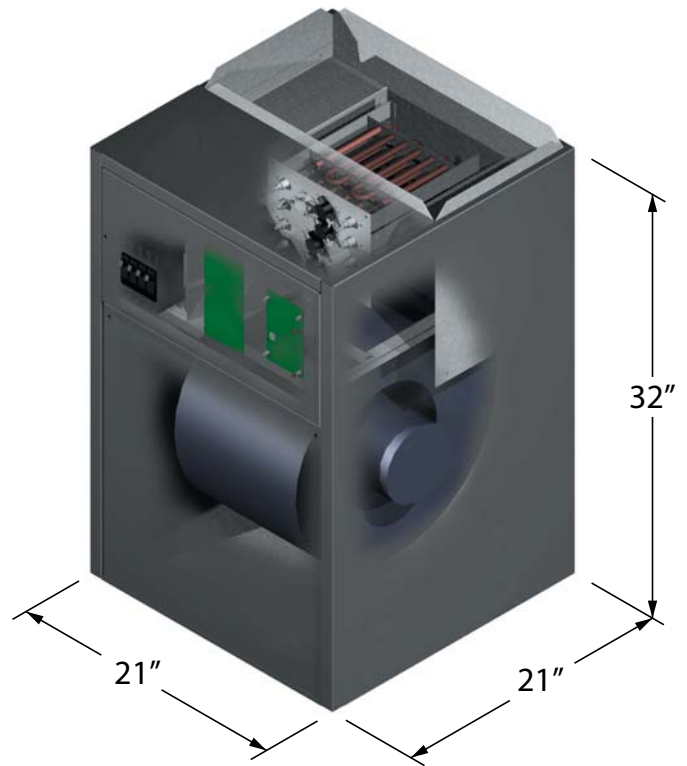

## Features only found on this product:

- WarmFlo technology
- Supply and outdoor temperature sensing
- GE ECM blower motor
- Electro blower control/programming
- Circuit breakers
- Standard Electro Load Control connections
- 10, 15, 20 kW sizes
- 1½-ton to 5-ton blower speed selection
- Compact cabinet
- Easy access panel doors
- Easy interface with ultraviolet air purifier and humidifier
- AC coil goes on top, HP coil needs inlet adapter (next page)

Can relate to AC only, if heat is not controlled

## Make-Up Air Package

With an appropriate inlet damper, insulated inlet ducting, high quality (washable or moisture tolerant) filter, and correct WarmFlo program chip; this unit can be mounted in any physical orientation for mechanical ventilation. This air handler provides the same Electro Industries' make-up air concept with controlled electric element modulation operating efficiency.

- WarmFlo controller - heated outlet air is continually monitored and adjusted to use a minimum electric energy. Real time kW usage depends upon temperature differential and is automatically adjusted.
- ECM variable speed blower - highest efficiency blower motor, field CFM selection allows matching to the mechanical ventilation discharge unit. Six selection steps from 700 to 1,500 CFM.
- 10, 15, or 20 kW models



**Electro**

Providing Comfort Through  
Efficient Energy Solutions

## Optional Cabinets

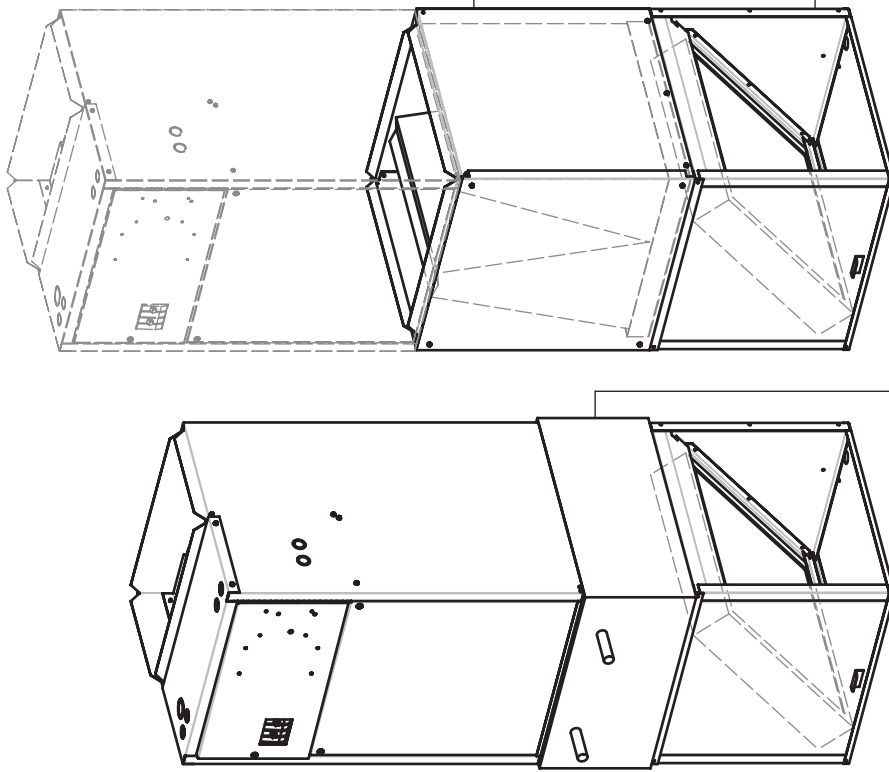

### HYDRONICS, HE-IWC-21

This cabinet includes a water coil as shown. The return air connection must be on the bottom which allows coil draw-through. The inlet for this cabinet is sized for an externally installed packaged return air filter cabinet.

### AIR FILTER, HE-IF-21

This cabinet includes a standard 2" or 4" x 20" x 20" pleated filter. The cabinet has adjustable filter rails to accommodate filters that vary in thickness.

### HEAT PUMP, HE-ICC-21

This cabinet can be configured between the Air Handler inlet and the filter cabinet. This section allows for a field installed 20"W x 20-1/2"D x 21"H standard drip pan A or N-coil. For horizontal applications the installer furnished coil must have proper drip pan.

## Specifications

Model	kW	Btu/h	Motor	Amps	Volts	Breakers
HE-(H,A)-10-21	10	31,000	1/2 HP	42	240	60
HE-(H,A)-15-21	15	51,000	1/2 HP	63	240	60, 30
HE-(H,A)-20-21	20	68,000	1/2 HP	83	240	60, 60
HE-E-10-21	10	31,000	1/2 HP	42	240	60
HE-E-15-21	15	51,000	1/2 HP	63	240	60, 30
HE-E-20-21	20	68,000	1/2 HP	83	240	60, 60
HE-N-00-21	N/A	N/A	1/2 HP	8 (max)	120	N/A

- 21"W x 32"H x 21"D • 1/2 HP GE ECM motor
- 100 lbs. • 700-1500 CFM

## Additional Information

The heat pump inlet section (HE-ICC-21) applies to split heat pump. For non-dual heat pump applications, this provides the full WarmFlo technology performance and comfort. The electric heat section is used to "temper" the air source heat pump output thus allowing heat pump to operate down to 0° F. Increase the heat pump higher efficient usage without sacrificing distribution air comfort.

This unit can also be configured without electric elements. By adding a water coil (see HE-IWC-21) the features of ECM variable speed blower, etc. can also apply. If the water coil is added to the inlet (between filter and blower) a standard air conditioning coil can be installed at the top or outlet.



**ELECTRO INDUSTRIES, INC.**

2150 West River Street, PO Box 538, Monticello, MN 55362  
763.295.4138 • 800.922.4138 • fax 763.295.4434  
sales@electromn.com • www.electromn.com