Electro-HELPS XV

 **Made in USA**



ELECTRO-BOILER SPECIFICATIONS

A complete product line to fit all your application needs

The Electro-Boiler™ has been heating America's homes and businesses since 1980. We take pride in our craftsmanship and we use only the best materials to ensure a high quality product. We are committed to you and we are confident that you will be completely satisfied with the Electro-Boiler.

Submittal Sheets are available for each model at
www.electromn.com



Electro
*Providing Comfort Through
Efficient Energy Solutions*

MINI-BOILER* MECHANICAL

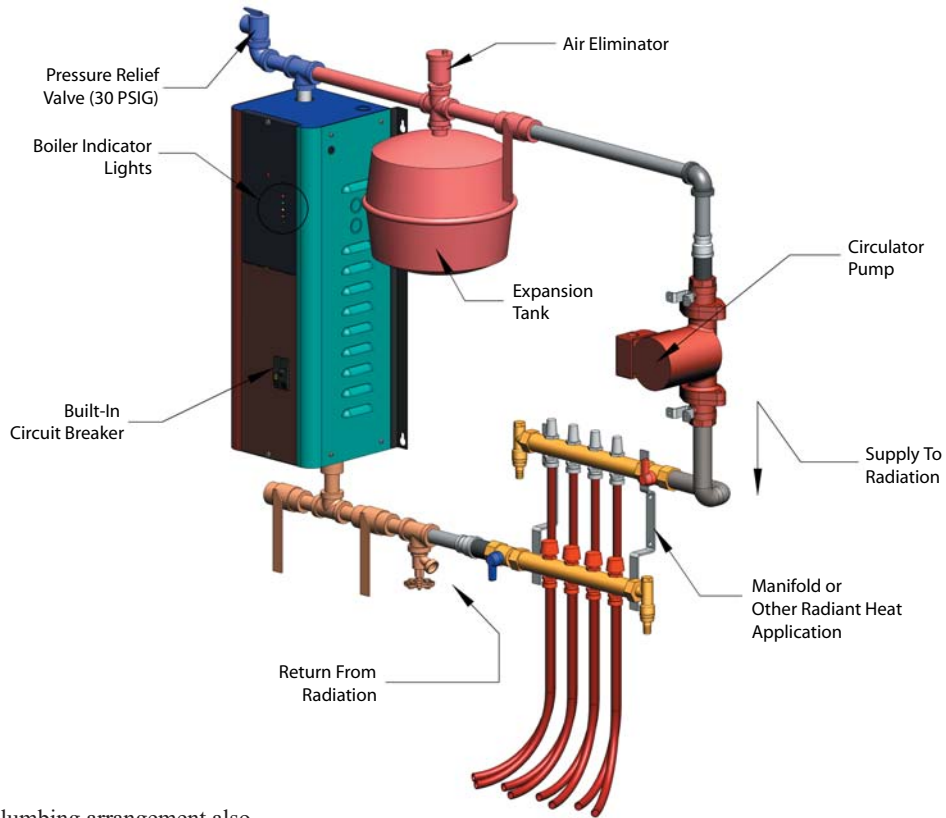

*This plumbing arrangement also applies to the Midsized boiler.

ART-238-00 2.0

MINI-BOILER ELECTRICAL

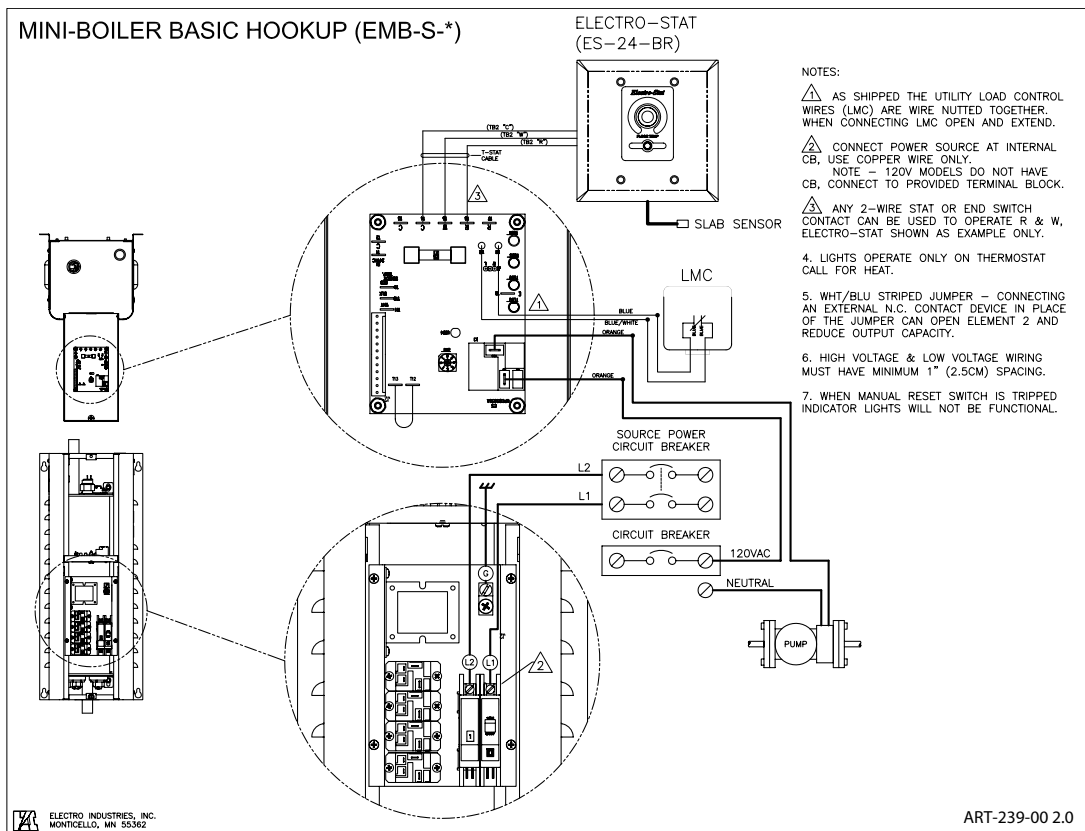

ELECTRO-BOILER MECHANICAL

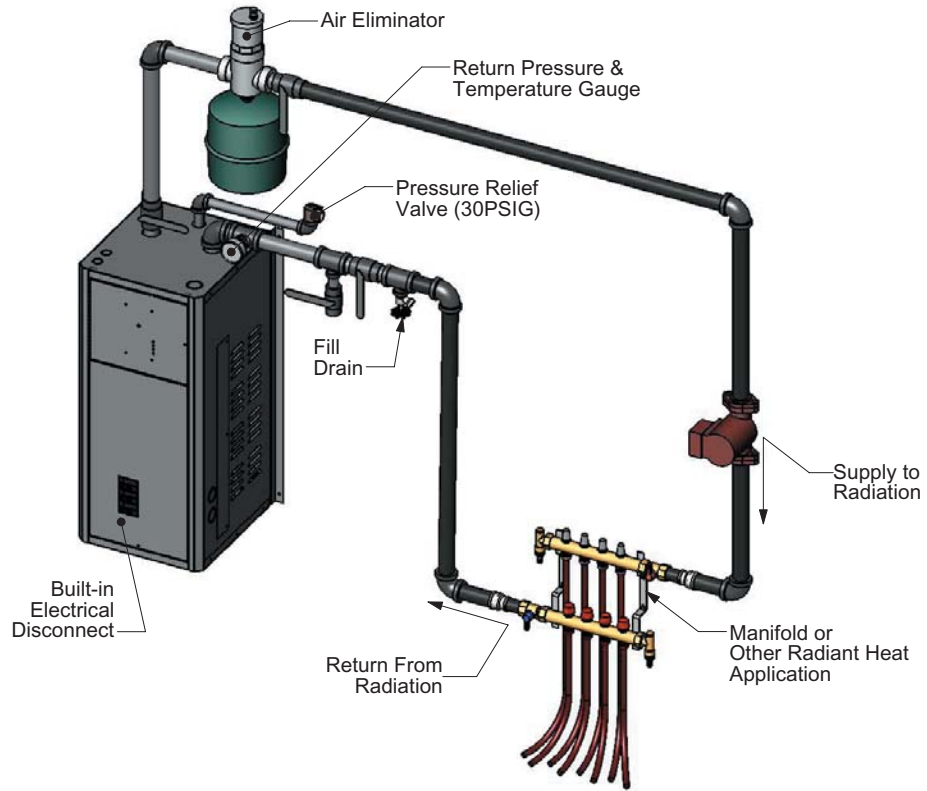

ELECTRO-BOILER ELECTRICAL

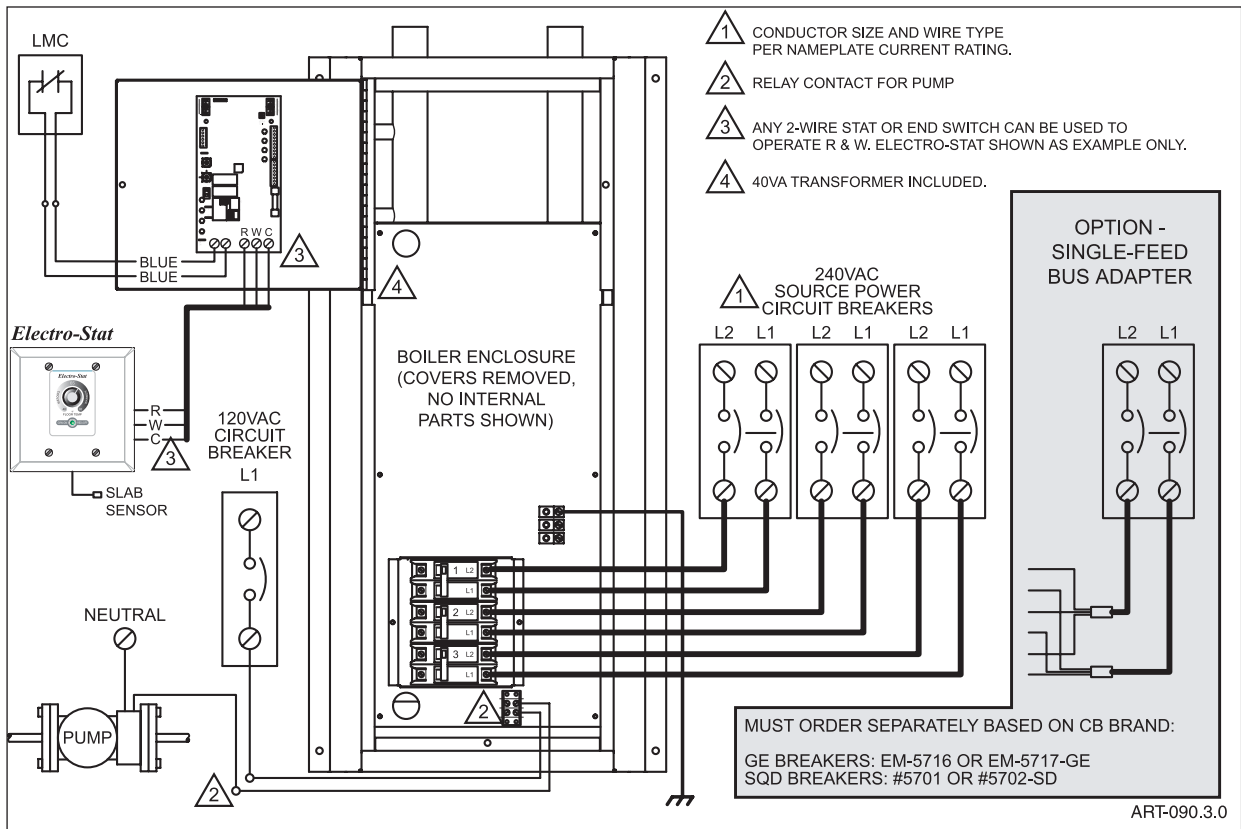



MINI-BOILER SERIES

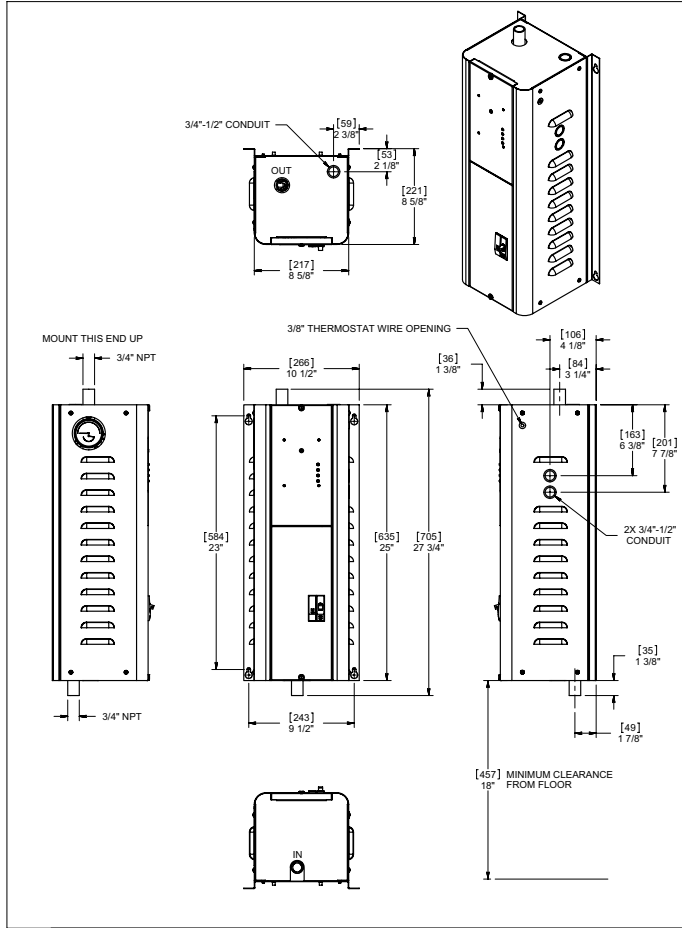

STANDARD EQUIPMENT

- Controls and control wiring terminals
- LED indicator lights
- DC Power Relays
- Hi-limits: 1st - automatic reset
2nd - manual reset
- Circulator switching relay - 10-amp maximum
- Thermostat or end switch connection (R and W)
- Load management control provisions
- Heavy duty sheet metal enclosure
- 1 gl. Steel vessel ASME "H" Stamp (20-year warranty)
- Supply pressure/temperature gauge
- Safety relief valve (30 PSI)
- Heating elements (20-year warranty)
- 2-year parts warranty
- Supply water sensing
- Temperature range 90° F to 160° F

EMB-W-9

- Senses target supply temperature and modulates electric element
- Temperature range 85° F to 150° F

WATER FLOW REQUIREMENTS

Model	Water Temperature Rise											
	Flow - 10° F/6° C		Head Loss		Flow - 20° F/11° C		Head Loss		Flow - 30° F/16° C		Head Loss	
	gpm	lpm	ft	m	gpm	lpm	ft	m	gpm	lpm	ft	m
EMB-S-1	.75	2.83	.01	.003	.37	1.39	.003	.001	.25	1.89	.003	.001
EMB-S-2	1.7	6.43	.01	.006	.85	3.21	.02	.006	.56	2.11	.004	.001
EMB-S-4	3.41	12.88	.08	.024	1.70	6.42	.04	.012	1.13	4.27	.02	.006
EMB-S-5	3.07	11.60	.06	.018	1.53	5.78	.02	.006	1.02	3.85	.02	.006
EMB-S-7	4.78	18.06	.12	.036	2.39	9.03	.06	.01	1.59	6.01	.02	.006
EMB-S-9	6.14	23.20	.23	.07	3.07	11.60	.10	.03	2.04	7.71	.06	.018
EMB-W-9	6.14	23.20	.23	.07	3.07	11.60	.10	.03	2.04	7.71	.06	.018

Note: Head Loss based on 110° F return temperature.

ELECTRIC SUPPLY

Model	Volts	Watts	Amps	kW	Phase	Btu/h	CB
EMB-S-1	120	1,100	9.17	1.1	1-60	3,754	N/A
EMB-S-2	120	2,500	20.83	2.5	1-60	8,532	N/A
EMB-S-4	120	5,000	41.67	5	1-60	17,065	N/A
EMB-S-5	240	4,500	18.75	4.5	1-60	15,358	30A
EMB-S-7	240	7,000	29.17	7	1-60	23,891	45A
EMB-S-9	240	9,000	37.5	9	1-60	30,717	60A
EMB-W-9	240	9,000	37.5	9	1-60	30,717	N/A

CLEARANCES

	MINIMUM CLEARANCE FROM COMBUSTIBLE SURFACES		SUGGESTED MINIMUM SERVICE CLEARANCE	
	0 INCH	0 MM	0 INCH	0 MM
BACK	0 INCH	0 MM	0 INCH	0 MM
LEFT	1 INCH	25 MM	6 INCHES	152 MM
RIGHT	1 INCH	25 MM	6 INCHES	152 MM
FRONT	1 INCH	25 MM	24 INCHES	610 MM
TOP	1 INCH	25 MM	24 INCHES	610 MM
BOTTOM	REQUIRED CLEARANCE - 18 INCHES/450 MM			



STANDARD EQUIPMENT

Staging - EB-MS-**

- Supply water sensing
- Regulates to front panel selected temperature
- Staging indicator lights
- DC Power Relays
- Hi-limits: 1st - automatic reset at 190° F
2nd - manual reset at 205° F
- Circulator switching relay - 10-amp maximum
- Thermostat or end switch connection (R and W)
- Utility load control provisions
- 2.2 gl. Steel vessel ASME "H" Stamp (20-year warranty)
- Supply temperature/pressure gauge
- Safety relief valve (30 PSI)
- Optional standby boiler control kit, plug-in
 - Standby switch and boiler contact

Modulating - EB-MA-**

- Same as EB-MS-** PLUS
- Modulates at a tighter temperature control
- Standby control package

Modulating - EB-MO-**

- Same as EB-MA-** PLUS
- Outdoor sensing with outdoor reset capability. The target supply temperature ramps up as it is colder outside.

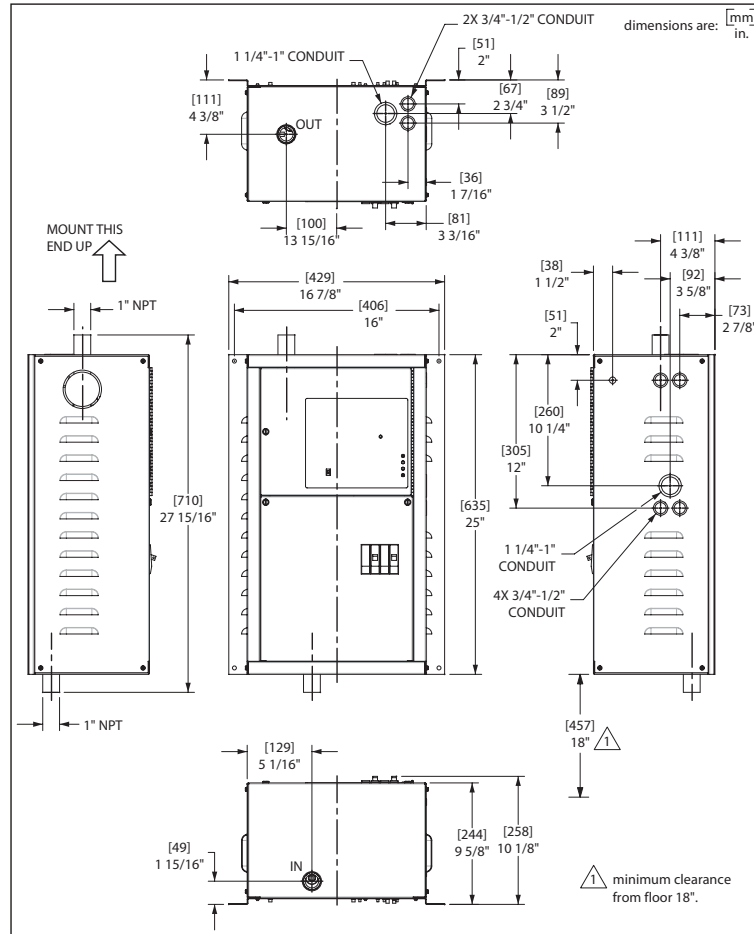

WATER FLOW REQUIREMENTS

Model	Water Temperature Rise											
	Flow - 10° F/6° C		Head Loss		Flow - 20° F/11° C		Head Loss		Flow - 30° F/16° C		Head Loss	
	gpm	lpm	ft	m	gpm	lpm	ft	m	gpm	lpm	ft	m
EB-M*-10	6.82	25.82	.01	.003	3.41	12.91	.004	.001	2.27	8.59	.001	.001
EB-M*-15	10.23	38.73	.03	.009	5.11	19.34	.01	.003	3.41	12.91	.004	.001
EB-M*-20	13.65	51.66	.07	.02	6.82	25.01	.02	.006	4.55	17.22	.01	.003

* = S, A, or O

Note: Head Loss based on 110° F return temperature.

ELECTRIC SUPPLY

Model	Volts	Watts	Amps	kW	Phase	Btu/h	CB
EB-M*-10	240	10,000	41.66	10	1-60	34,130	60
EB-M*-15	240	15,000	62.50	15	1-60	51,195	60 + 30
EB-M*-20	240	20,000	83.33	20	1-60	68,260	60 + 60

* = S, A, or O

CLEARANCES

	MINIMUM CLEARANCE FROM COMBUSTIBLE SURFACES		SUGGESTED MINIMUM SERVICE CLEARANCE	
	INCH	MM	INCH	MM
BACK	0	0	0	0
LEFT	1	25	12	305
RIGHT	1	25	6	152
FRONT	1	25	24	610
TOP	1	25	24	610
BOTTOM	REQUIRED CLEARANCE - 18 INCHES/457 MM			



TS SERIES

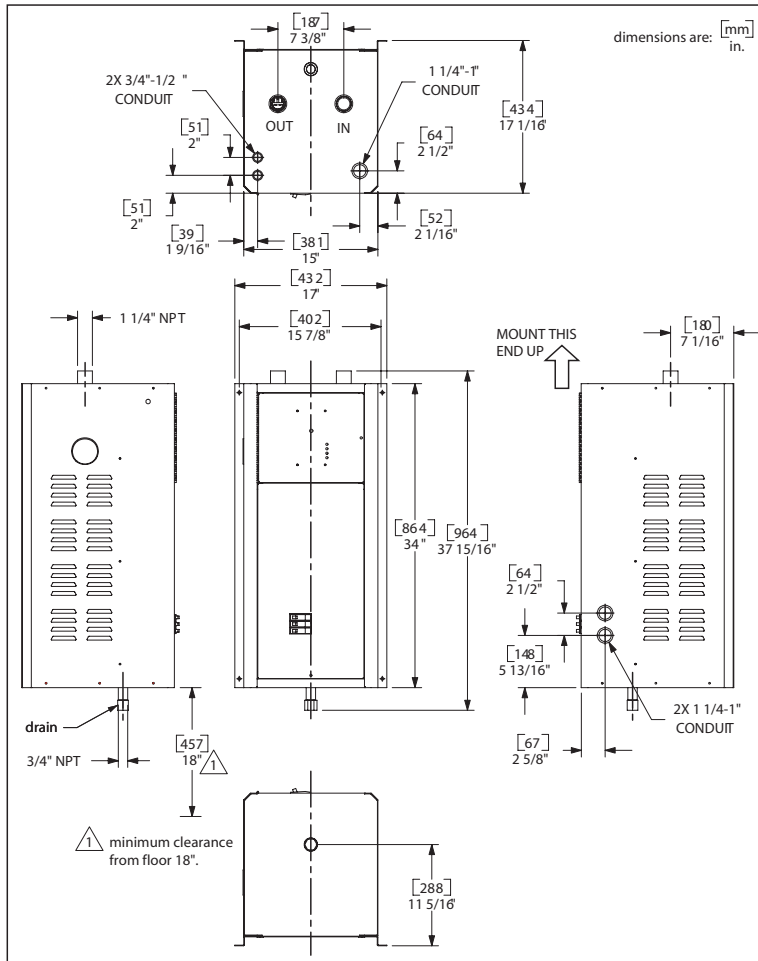

STANDARD EQUIPMENT

Staging - EB-S-**

- Supply water sensing
- Regulates to front panel selected temperature
- Staging indicator lights
- DC Power Relays
- Hi-limits: 1st - automatic reset at 190° F
2nd - manual reset at 205° F
- Circulator switching relay - 10-amp maximum
- Thermostat or end switch connection (R and W)
- Utility load control provisions
- 6.5 gl. Steel vessel ASME "H" Stamp (20-year warranty)
- Supply temperature/pressure gauge
- Safety relief valve (30 PSI)
- Optional standby boiler control kit, plug-in
 - Standby switch and boiler contact

Modulating - EB-WA-**

- Same as EB-S-** PLUS
- Modulates at a tighter temperature control
- Standby control package

Modulating - EB-WO-**

- Same as EB-WA-** PLUS
- Outdoor sensing with outdoor reset capability. The target supply temperature ramps up as it is colder outside.

WATER FLOW REQUIREMENTS

Model	Water Temperature Rise											
	Flow - 10° F/6° C		Head Loss		Flow - 20° F/11° C		Head Loss		Flow - 30° F/16° C		Head Loss	
	gpm	lpm	ft	m	gpm	lpm	ft	m	gpm	lpm	ft	m
EB-**-13	9.21	34.86	.03	.009	4.60	17.41	.01	.003	3.07	11.62	.004	.001
EB-**-18	12.28	46.49	.06	.018	6.14	23.24	.02	.006	4.09	15.48	.01	.003
EB-**-23	15.35	58.11	.09	.027	7.67	29.03	.02	.006	5.11	19.34	.01	.003
EB-**-27	18.43	69.77	.13	.039	9.21	34.86	.03	.009	6.14	23.24	.02	.006
EB-W*-13-2	9.21	34.86	.03	.009	4.60	17.41	.01	.003	3.07	11.62	.004	.001
EB-W*-27-2	18.43	69.77	.13	.039	9.21	34.86	.03	.009	6.14	23.24	.02	.006

** = S, WA, or WO

Note: Head Loss based on 110° F return temperature.

ELECTRIC SUPPLY

Model	Volts	Watts	Amps	kW	Phase	Btu/h	CB
EB-**-13	240	13,500	56	13.5	1-60	46,075	60 + 30
EB-**-18	240	18,000	75	18	1-60	61,434	60 + 60
EB-**-23	240	22,500	94	22.5	1-60	76,792	60 + 60 + 30
EB-**-27	240	27,000	113	27	1-60	92,151	60 + 60 + 60
EB-W*-13-2	208	13,500	37.5	13.5	3-60	46,075	50
EB-W*-27-2	208	27,000	75	27	3-60	92,151	100

** = S, WA, or WO

CLEARANCES

	MINIMUM CLEARANCE FROM COMBUSTIBLE SURFACES		SUGGESTED MINIMUM SERVICE CLEARANCE	
BACK	0 INCH	0 MM	0 INCH	0 MM
LEFT	1 INCH	25 MM	12 INCHES	305 MM
RIGHT	1 INCH	25 MM	6 INCHES	152 MM
FRONT	1 INCH	25 MM	24 INCHES	610 MM
TOP	1 INCH	25 MM	24 INCHES	610 MM
BOTTOM	REQUIRED CLEARANCE - 16 INCHES/406 MM			



STANDARD EQUIPMENT

Staging - EB-CA-**

- Supply water sensing
- Regulates to front panel selected temperature
- Staging indicator lights
- Heavy duty contactors
- Hi-limits: 1st - automatic reset at 190° F
2nd - manual reset at 205° F
- Circulator switching relay - 10-amp maximum
- Thermostat or end switch connection (R and W)
- Utility load control provisions
- 13.1 gl. Steel vessel ASME "H" Stamp (20-year warranty)
- Supply temperature/pressure gauge
- Safety relief valve (30 PSI)
- Optional standby boiler control kit, plug-in
 - Standby switch and boiler contact

Staging - EB-CO-**

- Same as EB-CA-** PLUS
- Adds outdoor reset capability

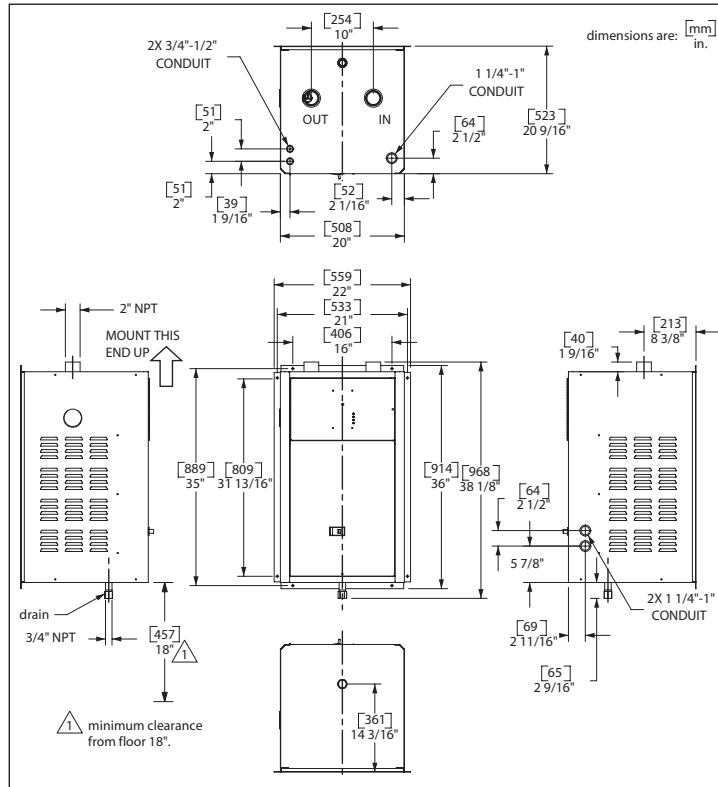

WATER FLOW REQUIREMENTS

Model	Water Temperature Rise											
	Flow - 20° F/6° C		Head Loss		Flow - 30° F/11° C		Head Loss		Flow - 40° F/16° C		Head Loss	
	gpm	lpm	ft	m	gpm	lpm	ft	m	gpm	lpm	ft	m
EB-C-18-48	6.14	23.24	.002	.0006	4.09	15.48	.001	.0003	3.07	11.62	.0008	.0002
EB-C-36-48	12.28	46.49	.01	.003	8.19	31.00	.004	.001	6.14	23.24	.002	.0006
EB-C-54-48	18.43	69.77	.02	.006	12.28	46.49	.01	.003	9.21	34.86	.01	.003
EB-C-27-20	9.21	34.86	.01	.003	6.14	23.24	.002	.0006	4.60	17.41	.001	.0003
EB-C-40-20	13.82	52.32	.01	.003	9.21	34.86	.01	.003	6.91	26.16	.003	.0009
EB-C-27-24	9.21	34.86	.01	.003	6.14	23.24	.002	.0006	4.60	17.41	.001	.0003
EB-C-40-24	13.82	52.32	.01	.003	9.21	34.86	.01	.003	6.91	26.16	.003	.0009
EB-C-31	10.75	40.69	.06	.018	7.16	27.10	.07	.021	5.37	20.33	.07	.021
EB-C-36	12.28	46.49	.06	.018	8.19	31.00	.06	.018	6.14	23.24	.07	.021

Note: Head Loss based on 110° F return temperature.

ELECTRIC SUPPLY

Model	Volts	Watts	Amps	kW	Phase	Btu/h	CB
EB-C-18-48	480	18,000	22	18	3-60	61,434	30
EB-C-36-48	480	36,000	44	36	3-60	122,868	60
EB-C-54-48	480	54,000	65	54	3-60	184,302	80
EB-C-27-20	208	27,000	75	27	3-60	92,151	100
EB-C-40-20	208	40,500	113	40.5	3-60	138,226	150
EB-C-27-24	240	27,000	65	27	3-60	92,151	80
EB-C-40-24	240	40,500	98	40.5	3-60	138,226	125
EB-C-31	240	31,500	131	31.5	1-60	107,509	100 + 80
EB-C-36	240	36,000	150	36	1-60	122,868	100 + 100

CLEARANCES

	MINIMUM CLEARANCE FROM COMBUSTIBLE SURFACES		SUGGESTED MINIMUM SERVICE CLEARANCE	
	INCH	MM	INCH	MM
BACK	0	0	0	0
LEFT	1	25	16	406
RIGHT	1	25	6	152
FRONT	1	25	24	610
TOP	1	25	24	610
BOTTOM	REQUIRED CLEARANCE - 16 INCHES/406 MM			

ZONE CONTROLLER

This will simplify your wiring and make zoning applications much easier. In addition, enhanced communicating features have the ability to stage the electric boiler based upon the connected zone capacity.

Standard Features

- Terminal block wiring, visual wiring layout
- Indicator lights showing zone operation
- 24-volt, 40VA transformer 120/208/240 connection
- Fuse protection
- Priority option
- Dual temperature operation
- Applies to digital or standard thermostats
- Dial switch, select each zone capacity



Pumps, Actuators, Valves

- EB-ZTA-1 - install within boiler cabinet
- EB-ZEA-1 - with enclosure and 40VA transformer
- EB-ZEA-2 - add additional 4, enclosure and 40VA

Pumps

- EB-Z2P - two pumps with priority and dual temp.

Zone Valves

- EB-ZTS-1 - install within boiler cabinet, encl. option
- EB-ZTS-2 - add additional 4, enclosure and 40VA

All Others

- EB-ZXA-1 - universal, pumps or valves, non-communicating, for any boiler
- EB-ZS-4 - automatic staging system for Brand X boilers or dual EB-R, -L, -E Series
- EB-ZC-4 - wiring and convenience interface, isolated boiler end switch
- EB-5415A - low cost, 2 or 3 zones, sheds one boiler stage (Mini-Boiler enhancement)

SLAB STAT

Sensing and controlling the system based upon radiant floor surface temperature or the concrete mass has very positive benefits. Radiant floor air stat in the same area as a forced air roomstat presents serious control problems. A remote sensing slab stat for the radiant floor removes this issue.

Remote sensing slab stat is required for storage applications.



ES-24-BR

SWITCHING RELAY - EE-5051

This DPDT 24-volt switching relay provides a convenient solution to any AC or DC application.



- **Ideal for zone pumps**
- 24V coil
- 120V, 10A, contact sets
- Easy to wire and nicely packaged

MULTI-BOILER - EB-C-STG5

Electrically connects between 2nd and 3rd, 3rd and 4th, etc.

OTHER OPTIONS

- SOT-1 Switchover to standby, total run time
- 5701 Single feed bus for 2 CB's (SQ-D CB)
- 5702 Single feed bus for 3 CB's (SQ-D CB)
- EB-S-SB Dual boiler option for EB-S Series
- WF-ANZ7 WarmFlo Analyzer, now applicable to WO and WA Series

CIRCULATING PUMPS

Electro stock includes three pumps sizes and three flange kit (with valve) sizes.



TO LOCATE A CONTRACTOR OR DISTRIBUTOR IN YOUR AREA VISIT WWW.ELECTROMN.COM AND CLICK ON DEALER FINDER

INSTALLATION PLUMBING KITS

For convenience of installation, Electro has plumbing kits tailored for each boiler series. See price sheet for various models and configuration.

Specifications subject to change without notice, all rights reserved.



ELECTRO INDUSTRIES, INC.

2150 West River Street, PO Box 538, Monticello, MN 55362
763.295.4138 • 800.922.4138 • fax 763.295.4434
sales@electromn.com • www.electromn.com